

JYHY26000(2V600Ah)

GENERAL FEATURES

- Absorbent Glass Mat (AGM) technology for efficient gas recombination of up to 99% and freedom from electrolyte for air transport-complies with LATA/ICAO Special provision A67.
- Not restricted for air transport-complies with LATA/ICAO Special Provision A67.
- UL-recognized component.
- Can be mounted in any orientation.
- Computer designed lead, calcium tin alloy grid for high power density.
- Long service life, float or cyclic applications,
- Maintenance-free operation.
- Low self discharge.
- Case and cover available in both standard and flame retardant ABS.

SPECIFICATION

Nominal voltage	2V	Dimensions	Total Height	14.45inches(367mm)
Rated capacity (10 hour rate)	600Ah		Height	13.0inches(330mm)
Number of cell	1		Length	11.9inches(302mm)
Approx. Weight (Kg / lbs)	38.5/84.9		Width	6.89inches(175mm)

Battery Dimensions

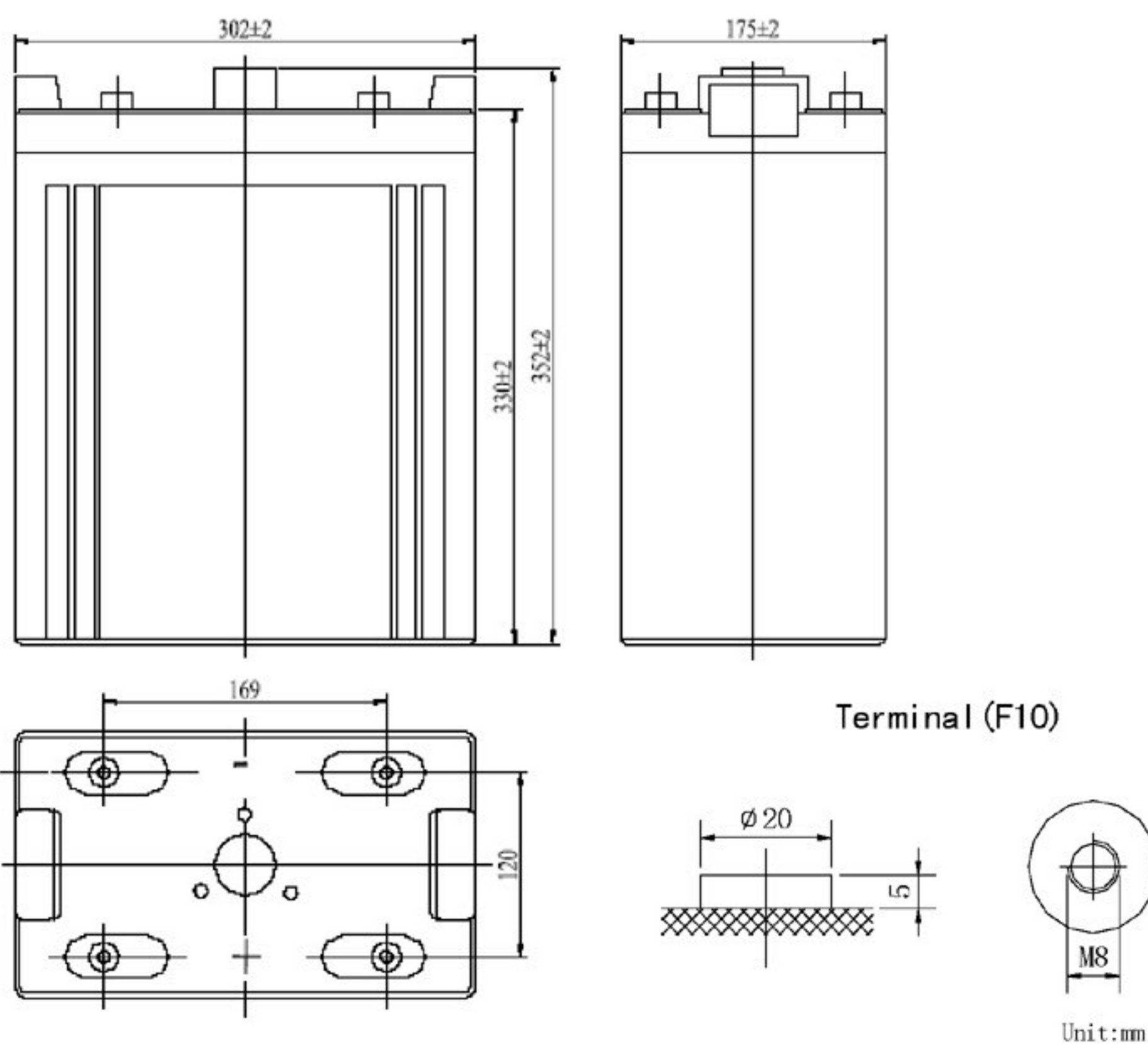

Total height with removeable cover: 367

Constant power discharge ratings-watts per cell at 25°C(77° F)

End Point Volts/Cell	5min	10min	15min	30min	45min	1h	2h	3h	5h
1.60V		1911	1424	1123	905	710	483	358	225
1.65V		1800	1347	1067	864	680	472	349	222
1.70V		1688	1269	1009	820	649	460	340	218
1.75V		1577	1191	951	776	617	446	330	214
1.80V		1467	1112	892	731	583	418	309	211

Characteristic

Capacity 77° F(25°C)	20 hour rate (31.5A、1.75V)	630Ah
	10 hour rate (60A、1.75V)	600Ah
	5 hour rate (105A、1.75V)	525Ah
	3 hour rate (155A、1.70V)	465Ah
	1 hour rate (370A、1.60V)	370Ah
	1C (600A、1.60V)	34min
Internal Resistance	Full charged Battery 77° F(25°C) : 1m Ω	
Capacity affected by Temperature (20 hour rate)	104° F(40°C)	102%
	77° F(25°C)	100%
	32° F(10°C)	85%
	5° F(-15°C)	65%
Self-Discharge 68° F(20°C)	Capacity after 3 month storage	90%
	Capacity after 6 month storage	80%
	Capacity after 12month storage	60%
Max. discharge current 77° F(25°C) : 1500A(5S)		
Charge (Constant Voltage)	Float: 2.25~2.30 V/77° F(25°C)	
	Cycle: 2.35~2.45 V/77° F(25°C) Max. Current: 120A	

